

**GreenTek®**

Trusted by the best in the game

# **SAREL ROLLER**

## **OPERATOR'S MANUAL**



# SAREL ROLLER

## INTRODUCTION

Thank you for purchasing the Sarel Roller. This British designed and manufactured product has been engineered to give years of use, provided it is used and maintained correctly.

As with all tractor-mounted equipment it is essential that all operators read and follow these instructions in order to use the Sarel Roller safely without endangering themselves or other persons.

## MACHINERY MARKINGS

Your machine carries the following information. Please quote your Serial Number when ordering spare parts.

CE <b>GreenTek</b>	
Manor Farm, Otley Road, Leeds, LS16 7AL, UK Telephone: 0113 267 6000	
YEAR <input type="text"/>	WEIGHT AS SUPPLIED <input type="text"/> Kg
MODEL <input type="text"/>	SERIAL No <input type="text"/>
INSPECTED BY <input type="text"/>	

## APPLICATION

The Sarel Roller is a unique dual purpose aerator which can be used either with the brush folded out for light brushing or with the brush folded on the centre frame for aeration only

This equipment is designed solely for aerating sports and amenity turf. Use in any other way is contrary to the intended use. The manufacturer accepts no liability for damage or injury resulting

from misuse. Compliance with the instructions in this manual is essential for safe operation.

**GreenTek**<sup>®</sup>

Trusted by the best in the game

**Tel:** +44 (0)113 267 7000

**Email:** [info@greentek.uk.com](mailto:info@greentek.uk.com)

**Web:** [www.greentek.uk.com](http://www.greentek.uk.com)

## SAFETY WARNINGS

### General

This turf maintenance system is designed to be operated by a tractor of not less than 17HP with a hydraulic lifting capacity of at least 450kg. Front weights may also be necessary when operating this machine.

All operators must also read and follow all instructions in the operators' handbook supplied with the tractor.

### Before Starting the Tractor Engine

Check that the brakes are applied, drives are in neutral, guards are in position and intact and bystanders are clear of the machine. Do not run the engine in a building without adequate ventilation.

### Operating the Machine

Always wear suitable protective clothing (eg, gloves and steel toe-cap footwear) when operating sharp or heavy machinery.

Before moving the machine, check to ensure that all the parts are in good working order, paying particular attention to tyres, steering, brakes and lights. Double check that the attachment is fitted securely to the tractor 3-point linkage.

Always observe the Highway Code both on and off the roads. Keep alert and aware at all times. Remember that some people are deaf or blind; that children and animals can be unpredictable. Keep travelling speeds low enough for an emergency stop to be effective and safe at all times.

Take special care when reversing and ensure that the area behind is clear of obstructions. Remove or avoid obstructions in the working area.

### Leaving the Driving Seat

Park the tractor on level ground. Before leaving the driving seat, stop the engine and make sure all moving parts are stationary. Apply brakes and disengage all drives. Remove the ignition key.

### Slopes

*Always take extra care when working on slopes*

Local undulations and sinkage will change the general slope. Avoid ground conditions which will cause the tractor to slide or roll over. Apply brakes before disengaging tractor gears. Keep the tractor completely under control when disengaging the traction clutch. Remember that the extra weight of the attachment will affect the balance and stability of your tractor.

# SAREL ROLLER

- Do take care when unfolding/folding brush section
- Do inspect the spikes and roller regularly for damage/wear
- Do remember the operating width
- Do inspect the brush regularly for damage/wear
- Do not use if any repairs are necessary

## Removing the attachment from the tractor

Lock down all of the drop legs BEFORE uncoupling the attachment from the 3-point linkage.

*Remember: it is operator's responsibility to always ensure that this machine is in safe working order before use and that conditions are suitable for it to be used without endangering the operator or others.*

## WARNING DECALS

The following decals are affixed to your Sarel Roller which must be obeyed at all times. Replacement decals are available free of charge from the manufacturers.

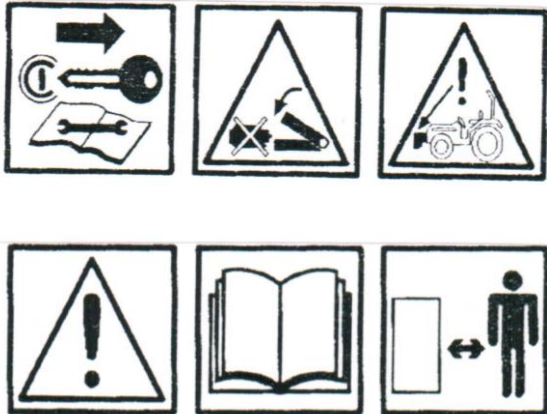

### **WARNING**

**IT IS THE OPERATORS  
RESPONSIBILITY TO ALWAYS  
ENSURE THAT THIS MACHINE IS  
IN SAFE WORKING ORDER BEFORE  
USE AND THAT CONDITIONS ARE  
SUITABLE FOR IT TO BE USED  
WITHOUT ENDANGERING THE  
OPERATOR OR OTHERS**

**GreenTek**<sup>®</sup>

Trusted by the best in the game

**Tel:** +44 (0)113 267 7000

**Email:** [info@greentek.uk.com](mailto:info@greentek.uk.com)

**Web:** [www.greentek.uk.com](http://www.greentek.uk.com)

## BEFORE USE - FITTING TO TRACTOR

The Sarel Roller is intended to be used with 4WD compact tractors and certain Utility trucks. It is essential that operators follow all safety procedures set out in the tractor operators' manual.

The Sarel Roller simply attaches to any Category 1, 3-point linkage by means of conventional top and bottom link pins.

- Do tighten anti-sway chains and lock the 3 stand legs into their raised position.
- Do ensure that the linkage is adjusted correctly so that the Sarel Roller frame hangs level from side to side.
- Do adjust the top link so that the centre post to which it attaches is vertical when in operation.

## USING THE SAREL ROLLER

For normal light aeration, lower the Sarel Roller to the ground and travel in straight lines across the area to be aerated the light weight trailing brush may be used for brushing dew into the holes if required.

If more intense aeration is required, a second or third pass over the same area will be necessary.

If heavy or deeper aeration is required, ballast weight may be added to the weight tray of the Sarel Roller.

- **Do not** attempt to turn when the Sarel Roller is in the ground.
- **Do not** reverse when the Sarel Roller is in the ground and the brush is in operation.

## UNCOUPLING THE SAREL ROLLER

To uncouple the Sarel Roller from the tractor, first lift the 3-point linkage, then fully lower and securely lock down all drop legs. Then lower the mainframe and uncouple from the tractor.

**NEVER UNCOUPLE THE SAREL ROLLER FROM THE TRACTOR UNLESS ALL DROP LEGS ARE SECURELY LOCKED DOWN.**

## MAINTENANCE

Pressure wash all debris off the brush after each time of use, this will considerably extend brush life. However, do not point the jet directly at the brush backs.

Lock the stand legs in their lower position before uncoupling the Sarel Roller from the tractor and always store in this position, with the brush held clear of the ground.

# **SAREL ROLLER**

## **PARTS LISTING FOR SAREL ROLLER**

<b>Item</b>	<b>Part No</b>	<b>Description</b>
1	SR 001	MAIN FRAME
2	SR 002	SPIKED ROLLER
3	SR 009	ROLLER MOUNTING
4	SR 003	SUPPORT LEG
5	SR 004c	SUPPORT LEG PIN
6	SR 010c	R clip
7	SR 007c	LOWER LINK PIN
8	SR 006c	LYNCH PIN
9	SR 005c	TOP LINK PIN
10	NOT REQUIRED	STOP BOLT ASSY
11	SR 011	ROLLER BEARING
12	SR 012	MOUNTING PIN
13	SR 013	WEIGHT TRAY/GUARD
14	SR 014	BOLT ASSEMBLY
	SR 015	DEW BRUSH

To order spare parts please email [spares@greentek.uk.com](mailto:spares@greentek.uk.com) or call +44 (0)113 267 7000.

**GreenTek**<sup>®</sup>

Trusted by the best in the game

**Tel:** +44 (0)113 267 7000

**Email:** [info@greentek.uk.com](mailto:info@greentek.uk.com)

**Web:** [www.greentek.uk.com](http://www.greentek.uk.com)

# SAREL ROLLER

## PARTS DIAGRAM FOR SAREL ROLLER

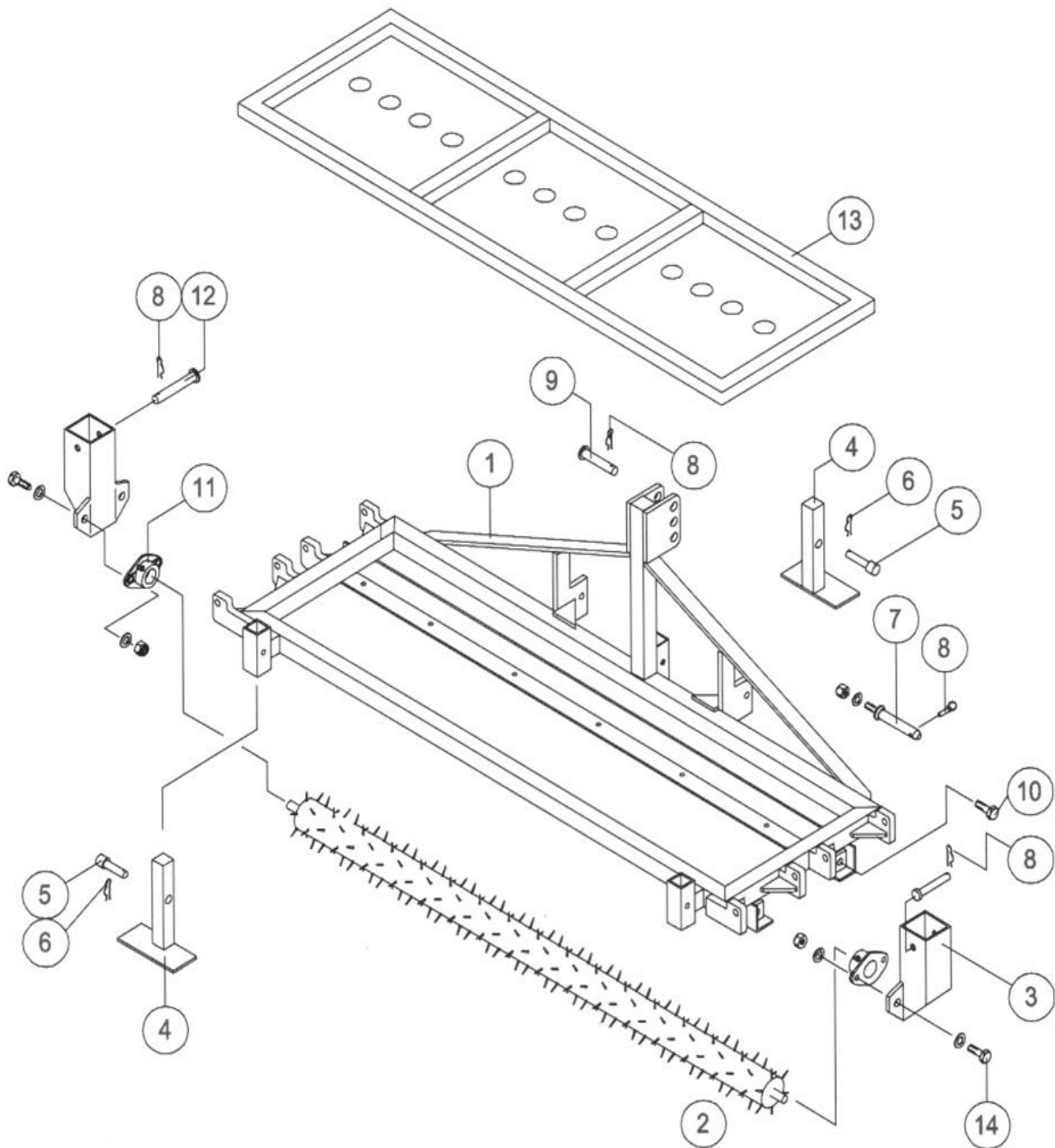

**GreenTek**<sup>®</sup>

Trusted by the best in the game

**Tel:** +44 (0)113 267 7000  
**Email:** [info@greentek.uk.com](mailto:info@greentek.uk.com)  
**Web:** [www.greentek.uk.com](http://www.greentek.uk.com)

# Certificate of CE Conformity

Date: 10 February 2003  
Machine Model: Sarel Roller  
Description: Tractor Mounted Aerator  
Serial Number:

I hereby certify that the machine detailed hereon conforms to European Directives 89/392EEC as amended on 91/368EEC – 93/368EEC – 93/68EEC.

Signed:  .....

(Quality Manager)



## **GUARANTEE**

We guarantee that should any defect in materials or workmanship occur within 24 months of the date of purchase we will repair, or at our option, replace the defective part free of charge provided that the fault is reported to us immediately it becomes apparent.

Damage caused by normal wear, misuse or in transit is not covered by this guarantee.

## **CONTACT US**

For further information, support or advice please contact:

[info@greentek.uk.com](mailto:info@greentek.uk.com)

+44 (0)113 267 7000